

Siemens PLM Software

# Plant equipment design and layout

## White Paper

Massive assemblies capability broadens footprint into plant equipment design and layout.

[www.siemens.com/plm](http://www.siemens.com/plm)

# Contents

<b>Introduction</b> .....	<b>3</b>
<b>Plant equipment design and layout</b> .....	<b>4</b>
<b>Plant equipment industry overview</b> .....	<b>5</b>
Design and engineering consulting companies .....	5
Machine design companies.....	5
Plant design companies .....	7
<b>Plant equipment design and layout tools available in Solid Edge</b> .....	<b>9</b>
Working with third-party data – translation .....	9
Large assembly layout capabilities.....	10
Display management capabilities .....	11
Efficient selection tools.....	11
Optimization capabilities .....	12
Large assembly drawing techniques .....	12
Digital analysis and engineering driven design tools .....	13
Revision management .....	14
Motion studies .....	15
Visualization.....	15
Managed design collaboration .....	16
Solid Edge and Femap .....	16
<b>Conclusion</b> .....	<b>17</b>
<b>Additional reading</b> .....	<b>18</b>
White papers .....	18
Case studies .....	18

# Introduction

For some time now, the advanced assembly design capabilities of Solid Edge® software have been used by many companies such as VAI, Anglo Platinum and Krones to layout their factory floors and design equipment for their plants. Solid Edge, a leader in massive assembly design with many customers creating assemblies of over 100,000 parts, now takes the next step to making it even easier to lay out

factory floors with actual machine geometry, as well as deal with other large assemblies in industries like heavy industrial vehicles, large mechanical machinery and process and power.

This white paper explores the plant equipment and layout design market and identifies the most common challenges and design problems typically associated with this industry.

# Plant equipment design and layout

A plant or factory is a collection of machines that work together to produce a finished product. A complete plant not only contains production machinery, but includes infrastructure such as power, cooling, waste and ventilation systems. One example of plant equipment design and layout is the layout and development of equipment to transform raw materials into a product through a series of punching, bending, rolling and heating steps.

Below are some examples of plants that may or may not produce a physical product. The most common types are manufacturing operations, but a less obvious example would be particle accelerators for physics research.

## Process

- Chemical processing
- Mining and quarry
- Particle accelerator

## Utilities

- Power generation
- Water treatment
- Waste handling

## Factories and manufacturing

- Production machines for consumer goods, pharmaceuticals, white goods, electronics
- Packaging machines for consumer products, food and beverages
- Raw materials production such as paper mill, textiles and steel

This white paper will explore the main classifications of these operations in terms of design requirements, and identify typical problems these segments face during

the design process. A list of functionality available from Solid Edge will be given and a brief explanation of the problems are addressed. A more detailed description of the specific capabilities found in Solid Edge that address plant equipment design and layout is provided at the end of this white paper.

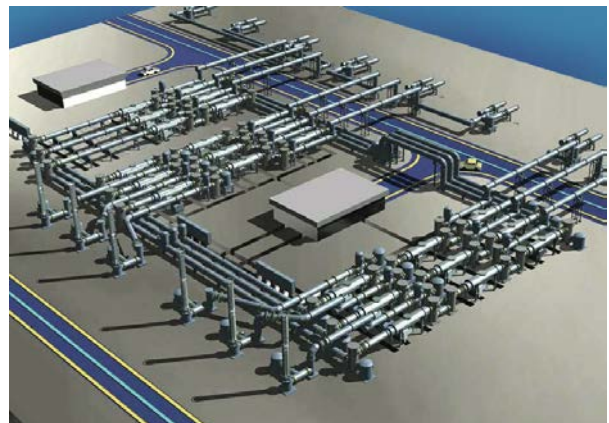
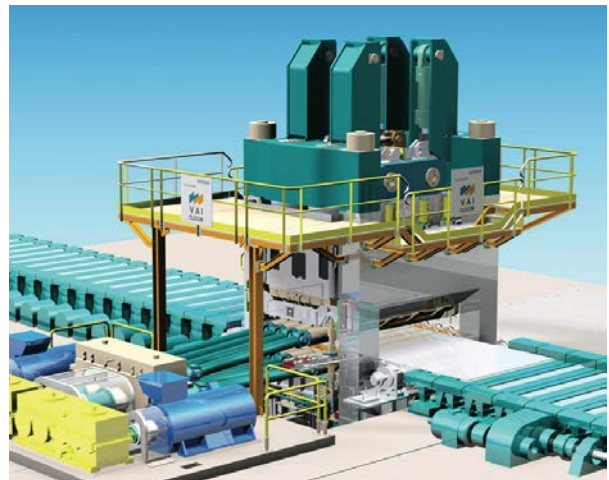

# Plant equipment industry overview

The plant equipment design industry is made up of three basic segments, each with their own challenges and requirements. While some of the design processes and issues are common across the various segments, this section points out some of the more salient issues. It should be noted that while specific capabilities in Solid Edge directly address the needs of plant equipment design and layout, these tools easily apply to any assembly design situation.

## Design and engineering consulting companies

Companies in this category include: contract architects, building contractors and machine design companies, usually employed by a large manufacturing company. Consultants identify the production process and develop factory floor layouts for material flow. Functional specifications are written for the machines which are outsourced. In most cases, factory designs only require material flows, space envelopes and auxiliary systems. They are responsible for coordinating equipment production and installation as well as overseeing the factory construction.

Consulting companies are generally smaller in terms of people and are tasked with conceptual design as well as obtaining project approval. Most likely initial 2D layout sketches are developed for equipment position and location, but these need to migrate into production designs. This is often a risky proposition for consultants as proposals must be made before any fit and position issues can be solved with 3D models.

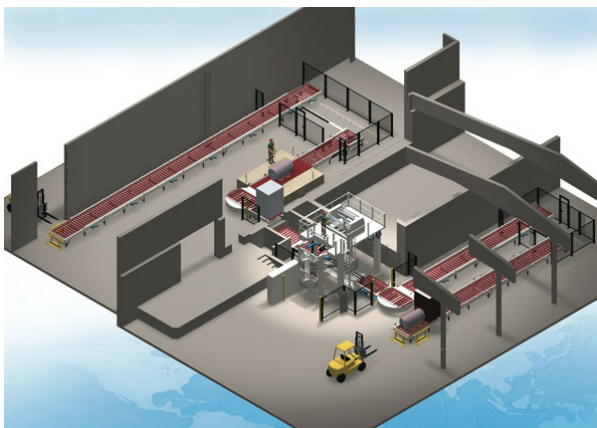

Often, simple 3D models of the machines are used to give a better sense of what the operation will look like. High quality renderings of a “completed” factory can enhance the overall presentation during the design review phase. With some simplified 3D models, fly-through animations are often used to show how people will work and how vehicles can move around the floor.

A large part of the design work for consulting companies is in the development of a 2D plan-view layout defining the entire operation. As there are often common subsystems for material handling, much data replication occurs but flexibility in copying while moving or rotating is necessary. While many companies work exclusively in 2D, the absence of 3D makes solving fit and position problems difficult.

As these companies contract work to many different vendors, several types of documentation are required such as detailed written specifications for machine vendors, 2D layouts for building fabricators and on occasion 3D drawings for component manufactures in cases where some design work is handled by the consulting firm. A not so obvious requirement resulting from this business model is hosting and managing design reviews across vendors to ensure machines are built to specification and schedules are maintained.

While the design challenges extend into other areas, the overview of this segment captures the major problems consulting firms face. To address these needs, Solid Edge includes a wide variety of functionality aimed at addressing: 2D factory layout design, factory mockup with fly-through, and supply-chain collaboration.

## Machine design companies

Companies in this market space specialize in the design and manufacture of production machinery. Their work demands detailed machine requirements and size restrictions supplied by either a consulting company or a contractor. Since these companies typically specialize in a particular type of machine such as packaging, stamping or folding, existing designs or technologies can often be leveraged into new projects. As with any typical machine design project, 2D data for the general material flow, size and connection

points are used to begin the design process. Companies such as AMF, Angelus Sanitary Can Machine Company, Changzhou Hengli Machinery and Doucet Machineries Inc. are good examples of machine manufacturers.

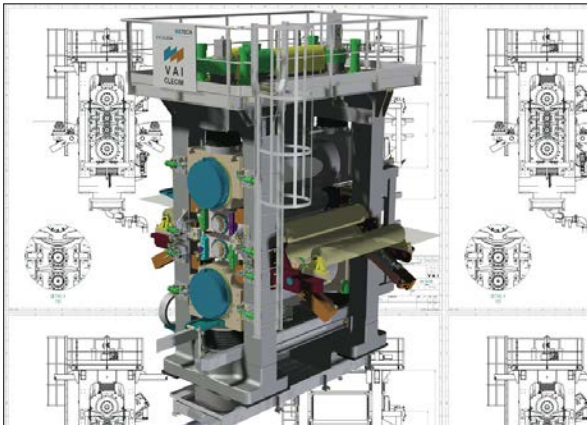

These types of companies generally have large design teams that span multiple disciplines including structural, motion, control systems and analysis. However, there is usually a single lead engineer assigned with managing the top level assembly and ensuring all subassemblies and systems are integrated and fit together. It's common practice that the lead designer initiates the design of a machine by outlining the material or product flow with a 2D sketch layout. Once created, individual subsystems are identified and component engineers begin developing each section for a complete digital mockup before manufacturing begins.

New projects often stem from an existing design and with a goal to swap systems and components with ones previously designed. This ala-carte approach reduces costs and lead-times; however, it's rare that all parts and systems are available and simply need assembling. During actual product development, heavy usage of standard parts, such as fasteners and bearings, are used.

The total number of parts in these types of machines can range from the hundreds to tens of thousands. The number of subassemblies can also vary depending on how the lead engineer organized the assembly structure, but re-use of parts and assemblies is a common practice. Designers strive to standardize components in order to reduce overall costs and machine lead time. Standardizing requires parts to be

created and stored so that they can be "tweaked" on the fly to accommodate future design scenarios.

Machines are typically high-cost items and custom developed for specific applications so they must be built to last. Years of nonstop operation is a laudable goal and to achieve this, components must be designed to handle all operating conditions. While most components are simply over-built, the effects of vibrations are not easy to account for. Modal analysis can be used to determine a part's natural frequency, and knowing those values will help designers understand where a component's "shaking point" is. Motion studies also help designers understand how moving parts interact.

In terms of machines that make something, the number of design reviews is proportional to the number of parts and systems. Expect a significant number of reviews when machines have several operations and part counts exceed 1000. The most common format for design reviews are 2D drawings. Review costs can be reduced by using 3D models and animations, simply because they are faster to create and are easier to change.

Most companies in this segment do their own manufacturing and assembly. While typical operations can include machining, welding, bending, rolling and other common steps, this subject is out of the scope of this white paper. Consult the Solid Edge Structural Frames and Weldments white paper for more details.

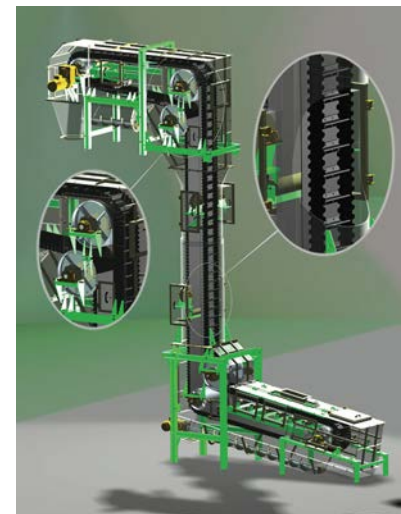
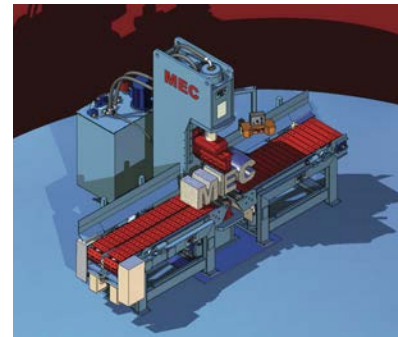

Perhaps the most expensive aspect of engineering is developing documentation. Most commonly it is in the form of 2D drawings, complete with orthographic drawing detail and auxiliary views – with full dimensions and annotations. While it's common to have one drawing per part, in many cases, complex components will require several drawing sheets. While these drawings are automatically created from 3D models, the process in pure 2D is laborious and lacks quick change.

It may not be obvious at this point, but one machine can have 10 subsystems, 100 subassemblies and thousands of parts and thousands of drawings, so managing this data is of prime concern. Finding, revising, vaulting, printing, archiving are just some of the needs here. This white paper will only outline high-level issues; refer to Solid Edge Large Assemblies for more details.

The design issues don't end here, but the main challenges such as data re-use, design with analysis and drawing

production have been identified. Solid Edge is the leader in providing a complete solution for machine design. Following this section is a complete list of tools and workflows specifically designed for this market.

#### Plant design companies

This final type of company is involved with all aspects of plant design ranging from building size definition, machine design, part production and machine installation. As expected, these companies are global in presence and have vast numbers of employees. While they might outsource some of the work, their main specialty is providing a turn-key solution for companies requiring either mass produced products or specialty processes. Some examples of these companies are Siemens, Beumer and Krones.

These companies face many of the same challenges as the previous operations, but host an additional set of issues. While tasked with consulting, they must also design and

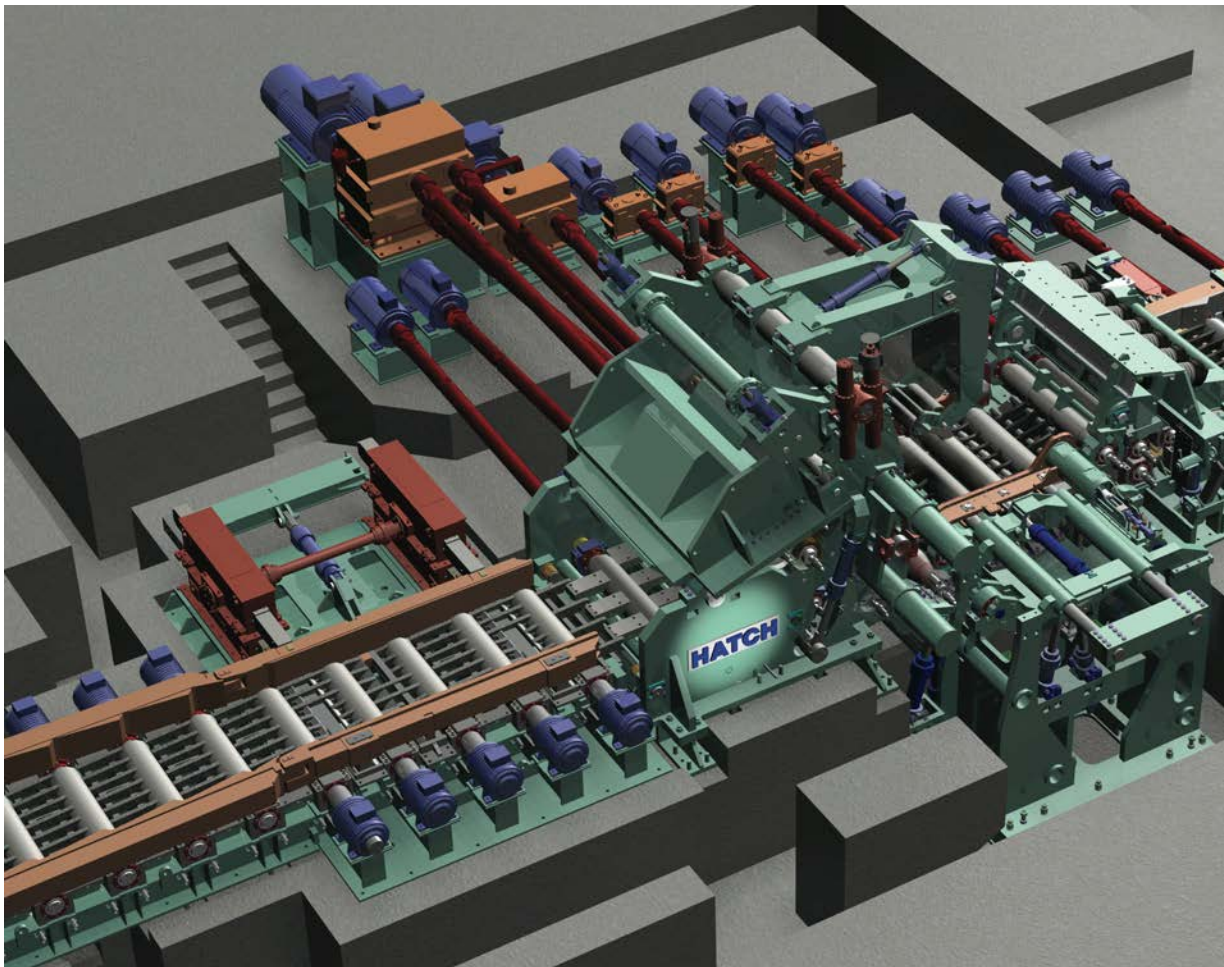

build the machines needed for the process. This section will not list the issues previously stated, but will only address new items.

Initial plant layouts are typically developed in 2D, but as these companies typically develop machines using 3D tools, the need to integrate 2D layouts with 3D models becomes obvious. Having this capability would allow fast factory floor layouts, while realizing the benefits of 3D such as visualization, solving fit and position problems and facilitating part manufacturing. Having the best of both worlds – a mix of 2D and 3D along with performance – is the ultimate goal.

One of the biggest hurdles these companies face is handling the amount of data associated with a plant. Multiple machines containing thousands of parts and the infrastructure, such as conveyors, electrical, plumbing and even some of the building structure, can easily grow a top-level assembly to 100,000 components. A complete 3D model will help validate clearances, as well as enable animated shop floor fly-throughs. Larger amounts of data require larger computers, but a more subtle need is special tools to make working with massive assemblies more productive.

Assemblies of plants with this many parts require huge design teams that generate massive amounts of data. While product data management (PDM) requirements are prevalent in all businesses, the need here is more prevalent due to complicated workflows, data being used by all parts of the organization and the amount of users accessing, editing and reviewing the data. This white paper will not attempt to explore product data management issues as they are detailed in a supplementary white paper on OEM Supply Chain Collaboration.

Because these companies tend to handle all aspects of design, analysis and manufacture, an integrated solution is considered to offer the most productivity. While most of the top systems have some level of integration between applications, there always seems to be issues with vendor support, licensing and release synchronizations.

Because of the size and complexity of companies in this segment, the issues and problems look endless. The main challenges, however, are integrating 2D layouts with 3D models, massive assembly support and fusing software systems for multiple disciplines. The Solid Edge CAD, CAM and PDM tools, coupled with Femap™ software for CAE, provide a complete solution portfolio for machine design.



# Plant equipment design and layout tools available in Solid Edge

The following section goes into more details and explains how technology in Solid Edge helps streamline plant equipment layout and the creation of equipment designs. These descriptions are intended to provide a high-level overview; more detailed information can be found in respective whitepapers and fact sheets listed later. Please ask your Channel Partner for a copy or download directly from [www.siemens.com/solidedge](http://www.siemens.com/solidedge).

Being able to model parts and assemble them onscreen is only part of the story when working with large assemblies. Importing third-party data is a necessity and without proper tools and techniques to help when working on large assemblies, sooner or later they become unwieldy and users will feel the system slowing down as resources run low. Solid Edge large assembly tools provide efficient handling and management of large complex assemblies and maximize available system resources to ensure successful completion of the largest projects.

## Working with third-party data – translation

Most companies collaborating in a supply chain do not always share the same design systems. Solid Edge provides both 2D and 3D translation capabilities that allow data to be used from other systems.

**Translating 2D** A streamlined 2D translation wizard ensures smooth data transfer from many popular 2D CAD applications such as AutoCAD (DWG), Micro station (DGN), DXF or IGES files. Drawings from AutoCAD for example appear the same as they did in native AutoCAD. All layers, line styles, fonts, dimensions, Xref's and Drawing sheets etc. are preserved.



**Translating 3D** Sometimes data needs to be acquired from OEM supply chain partners, but the OEM does not have control over its partner's design system. Solid Edge provides many native CAD translators such as NX™ I-deas™ software, Pro-E, Inventor and add-on tools for CATIA V4 and 5 as well as neutral file formats such as Parasolid® software, ACIS, IGES and STEP.

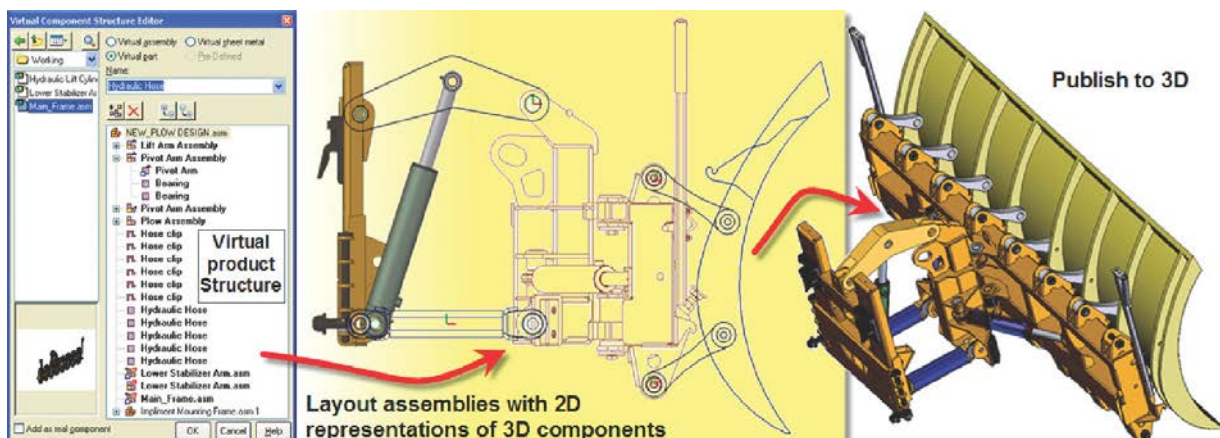
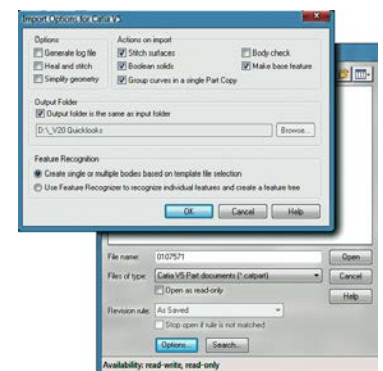

Once 3D data is imported into Solid Edge, powerful tools add additional intelligence and allow quick and easy editing. **Auto Constrain** adds parametric relationships to imported assembly files. OEM supply chains are able to assemble their designs in Solid Edge using both imported and Solid Edge native data to perform advanced operations on the combined assembly, such as full motion studies. For single part models, Direct Editing allows geometry to be directly changed, including functionality to move face, add draft angle, resize a hole and more.

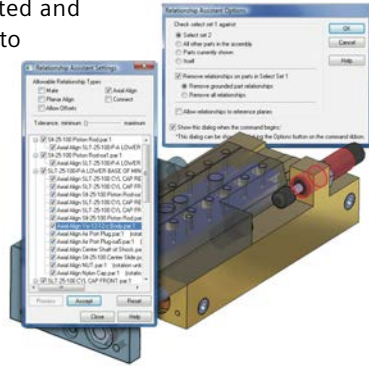

**Large assembly layout capabilities**

The tools described here are particularly suited to laying out machinery and equipment, but are not limited to this application; they are also useful in any assembly design task.

**Zero-D** Initial design concepts do not require any geometry to be created. Solid Edge frees designers from the overhead of creating geometry or files to create a product structure. We tend to think of design data as being a mix of 2D geometry and 3D models, but before either of these exists, another piece of information needs to be created. This is the assembly structure. For example, a lead engineer may sketch out what assemblies and components are to be used as a start point for a new design. There may even be some part numbers reserved and some other non-graphic information referenced, such as materials or supplier names. But at this point, it is a structure only. Nothing has been drawn or modeled. This is exactly what the Solid Edge virtual structure is all about.

**Hybrid 2D/3D** Not all design concepts lend themselves to be solved entirely in 3D. Solid Edge provides the flexibility to create a product structure before creating files or deciding their position. The unique Hybrid 2D/3D design approach in Solid Edge means engineers create virtual product

structures using Zero D to mix and match real and virtual components with 2D sketches and 3D parts to quickly lay out equipment and machine details against 2D plans. 2D parts sketches can be used to lay out virtual components before any 3D design is carried out. 2D part sketches are easily substituted for 3D designs once they start to take shape.

**Zones** Zones make working with massive assemblies even more manageable and boost performance, allowing designers to define a permanent range box to isolate areas of large designs they are responsible for at a subsystem level. Intelligent caching allows retrieval of only the parts in the zone, without having to open component files to determine if they lie in the zone or not. This creates a significant performance boost when switching zones or opening a massive assembly.

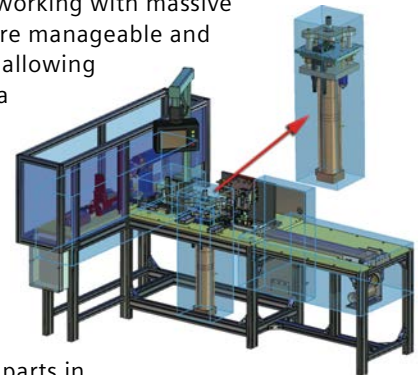

**Move/copy/rotate assembly command** To help designers lay out factory floors and/or machine designs, a new manual component positioning capability allows existing sub-

assemblies to be quickly copied, moved, rotated or arrayed within an assembly. To remove any restrictions, assembly relationships to existing components are ignored, while those integral to the subassembly remain intact. Subassemblies can be simply dragged to a new location or precisely moved using coordinates, vectors or exiting components.

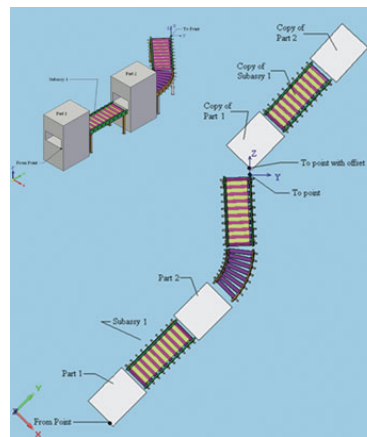

**Simplified parts and assemblies** This feature uses proprietary technology to simplify large assemblies into a single body to reduce design clutter, protect intellectual property, create fast layout drawings and make efficient use of system resources. Simplified assemblies allow designers to efficiently lay out large complex machinery using lightweight simplified designs. Simplified assemblies can be substituted for the final design if required.

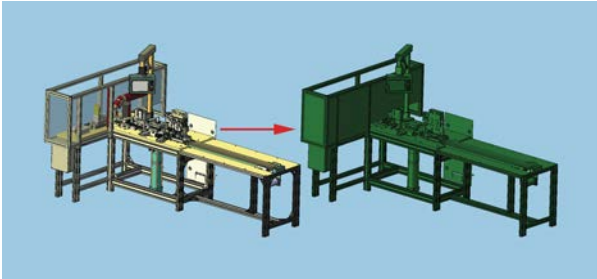

#### Display management capabilities

As assembly size grows, so do the number of tasks required to visualize only areas of the design or subsystem of interest. Without dedicated tool sets that allow efficient turning on or off components, or to effortlessly select certain areas of design, a simple design task becomes time consuming. Solid Edge provides many techniques for efficiently displaying areas of interest in a design without time consuming manual operations and provides a way to share manufacturing information in 3D.

**Configurations active/inactive** keeps components visible (for reference) while keeping system resources in check by unloading unnecessary component geometry

**Configurations show/hide** uses display configurations to control what parts are shown or hidden, enabling users to quickly remove display clutter (unnecessary parts)

**PMI sections** quickly 'section' 3D design and add PMI details if more design clarity is required

**Clipping planes** create 3D cross sections while designing

#### Efficient selection tools

Selecting components may seem like an obvious command to have in any 3D design system, but what many systems provide is limited to manual selection options or simple range box selection. To be truly efficient at adding or removing components from an assembly on the fly or to quickly save in display configurations, you need more



precise dedication tools. Solid Edge provides many options that can be used alone or in combination with each other.

**Select small parts** quickly selects all components that are smaller than a user defined size. Useful for removing small components like fasteners (that may not be seen) from an assembly display. This feature enables you to release system resources, as well as create drawings in less time.



**Select all identical parts** selects all the parts in the assembly which are identical to the part already selected.

**Query selection** finds and selects components by searching on component properties or attributes.

**Select visible parts** selects parts that are fully or partially visible in the active window at its current view orientation. This gives the ability to 'peel' away the external components, moving progressively into a design from the outside.

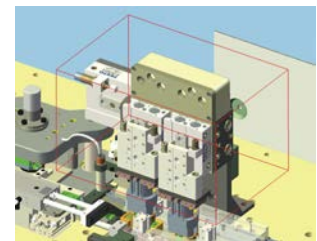

**3D box select** provides quick graphical selection of components being displayed.

**Groups allows** components to be 'grouped' together to make selection a single click process.

**Select options** provides the ability to not only 'show and hide' the components, but also 'show only' as well as 'zoom to' the selected part or 'scroll to part' which will expand the pathfinder assembly structure.

**Assembly pathfinder** keeps an assembly tree structured, and allows convenient selection of components from the assembly structure.

#### Optimization capabilities

To increase display performance on large assemblies, Solid Edge uses many innovative techniques that remove unnecessary detail while manipulating a view or change display quality.

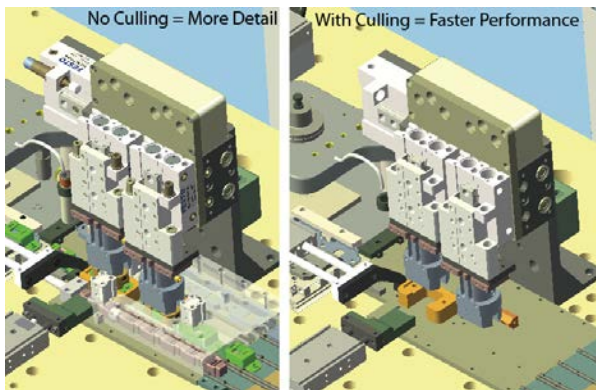

**Culling** instructs the display system to ignore display requests for certain small objects if it detects excessive overhead on display performance.

**Refresh scale** controls the speed and precision of the magnification commands, such as zoom area, zoom and fit.

Solid Edge also provides tools to change the display of the model for better clarity, such as **wire frame**, **wire frame with hidden edge display**, **shaded only** and **shaded visible hidden line** (VHL). While shaded models look nice, many engineers choose to work in wire frame for better clarity.

**Automatic part** unloading manages valuable system resources with no user effort by sensing automatically which parts are in use and dynamically loading or unloading their geometry from memory to improve performance. This feature is especially helpful when working with massive assemblies.

**64 bit** is the biggest impact on large assemblies/ drawing creation where resources run low in 32 bit. Most companies do not need 64 bit today, but those who do see a tremendous benefit – being able to process larger and larger assemblies and drawings.

#### Large assembly drawing techniques

Despite claims that 3D is all you need in the modern manufacturing environment, 2D drawings are still the currency of many manufacturing companies. Solid Edge provides the most complete standalone 2D, Hybrid 2D/3D and 2D from 3D drafting and detailing capabilities in its class. For machinery and equipment design, Solid Edge is able to draft the largest assembly or detail the most complex component with ease, including internationally recognized dimension, annotation and drawing standards, orthographic or isometric drawing views and BOMs.

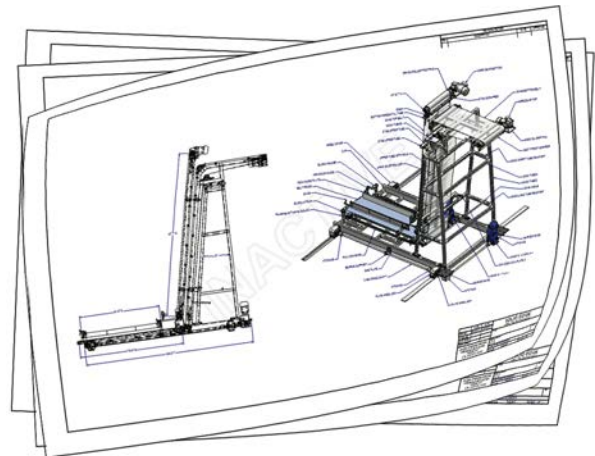

Solid Edge sets the standard for fast productive 2D drawing views. Drawings are a key part of the process for manufacture, inspection and documentation of designs – often the Achilles heel of many other 3D modelers. Solid Edge brings 2D and 3D together to provide speed and control of 2D drawings for the most complex of assemblies.

**Draft quality drawing views** ensure engineers can quickly set out drawing view composition, fast view placement and drawing updates. Fully associative parts lists with auto ballooning are also produced.

**Using simplified assemblies** allows Solid Edge to create the fastest 2D drawing views on the market. A simple option during drawing view creation enables

Solid Edge to create drawing views up to 60 times (typically 2-8X) faster than with all details on, without any appreciable difference in drawing view quality.

Unique architecture in Solid Edge Draft allows instant opening of drawings of massive assemblies, drastically decreasing drawing access time from minutes to seconds. **Drawing review mode** allows rapid opening of a drawing for reviewing, adding dimensions, measuring or printing regardless of how big or detailed the drawing is. Inactive drawings allow dimensions and annotations to be added, and part numbers and Bill of Materials to be extracted. Drawing Views can also be 'Activated' on the fly if needed to establish a 'true' dimension in an isometric view for instance.

Inactive drawings are ideal for:

- Drawing reviews with or without 3D
- Quick print jobs for the shop floor
- Continued detailing by teams without access to the 3D model

#### Digital analysis and engineering driven design tools

To reduce the need for physical prototypes, Solid Edge provides engineering tools that ensure components are designed right the first time. To ensure components are fit for their purpose, these tools either allow designs to be analyzed as they are developed, find engineering variables from a known target or 'engineer' components (such as shafts or gears) based on known engineering criteria like loads, speed and materials.

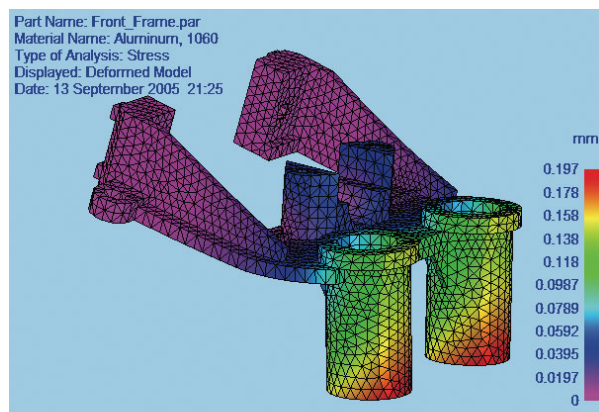

Created specifically for design engineers, Solid Edge Simulation software provides preconfigured, best-practice, process guidance to the user for simple finite element analysis integrated in Solid Edge. Using the same process-based approach found within other Solid Edge capabilities, finite element technology is presented to the user in an easy-to-follow step by step workflow using the patented SmartStep approach to walk designers through detailed analysis tasks. Analysis settings and results are stored with the component, so if the part changes, the results are modified without needing to repeat the process of applying loads and constraints. Detailed HTML reporting capabilities and animations capture response-due-to-analysis conditions and full documentation of the results, containing meaningful images of stress contours.

For more detailed and advanced analysis types including statics, modal, buckling, heat transfer and nonlinear studies, parts and assemblies can be associatively passed to Femap from Solid Edge. Full associativity is maintained between Solid Edge and Femap; all material properties and colors are transferred with the Solid Edge model.

Solid Edge **goal seeking** takes graphical engineering problem solving to a new level and avoids labor intensive iterative calculations by allowing design engineers to perform two- and three-dimensional what-if engineering calculations, with a combination of 2D and 3D parametric geometry, mathematical formulas, variables and part properties. Knowing the target value of an engineering calculation, goal seeking allows users to set certain parameters, while the system varies other factors to achieve the desired result. Goal seeking concepts, familiar to many in Excel spreadsheets, have now been applied to engineering and design by allowing engineers to solve problems that are best expressed graphically. Results can be used to drive 3D geometry in a true hybrid 2D/3D design environment.

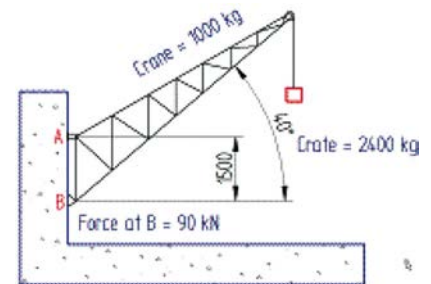

**Variable limits** allow users to establish limits on their Solid Edge variables, as well as definitions that specify these variables must have a discrete value from a list. By notifying the user when variable inputs are out of limit or not on the specified list, greater engineering integrity is achieved.

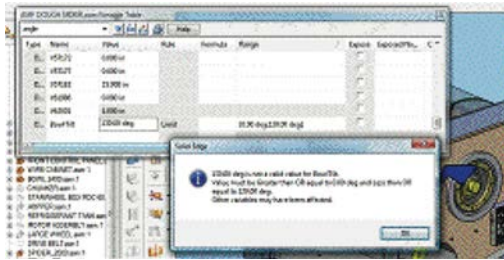

**Engineering reference** is a powerful, fully integrated calculation and formula-driven design tool for engineers and designers of machinery design components such as shafts, cams, gears and springs. Engineering Reference embeds a wealth of engineering reference information within Solid Edge to help engineers design by function as well as form. This tool allows Solid Edge users to employ engineering calculations to automatically create mechanically correct parts and re-use knowledge-based engineering principles.

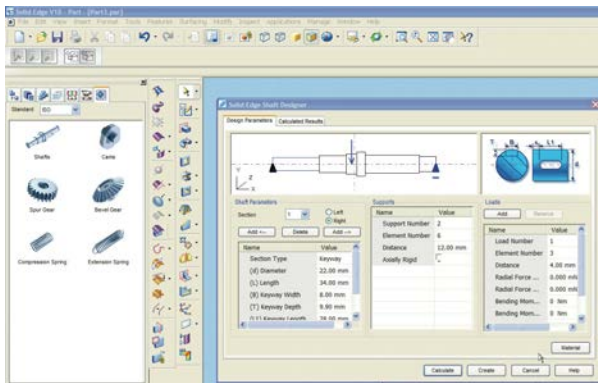

Engineering Reference supports industry standards including ANSI, DIN and JIS and helps engineers design, select and strength-check a broad range of common machinery components, including:

- Cams
- Shafts
- Spur gears
- Bevel gears
- Extension springs
- Compression springs

### Revision management

To make fast design changes or create a new project, start by creating a partial or complete copy of the project's documentation. After copying the documents, it's easy to begin changing the project's parts and assemblies. Revision manager displays a hierarchy of the related documents and contains tools to create new revisions of the documents while maintaining the links. Revision manager enables tasks such as:

- Copy and rename documents selected for revision to locations specified
- Update the specified revision and document numbers
- Update or maintain references in the document hierarchy
- Show the size of documents
- Copy a row or rows of data to the clipboard for printing
- Save previous query paths
- Preview a document

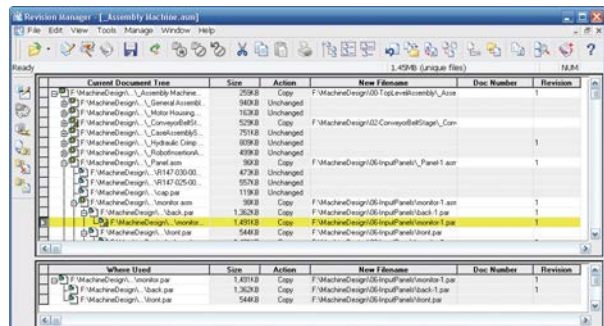

### Motion studies

Integrated explode, render and animation capabilities, combined with motion simulation, allow creation of dynamic photorealistic animations and motion studies using existing Solid Edge 3D models to share and articulate design ideas, reduce risk and generate new business.

Many companies already recognize the benefits of using 3D for design work. Solid Edge goes beyond building assemblies and allows companies to extend their CAD data to be used by design review teams, communicate and market their products, help manufacturing and instruct shop floor assembly workers and field engineers.

- Design review teams collaborate and share their products and ideas
- Project engineers/leaders visualize, communicate and market products internally or with customers and use engineering data to visualize designs and fix errors before building expensive physical prototypes
- Manufacturing engineers and process planners define tooling and production process, communicate design intent and manufacturing sequences (assembly/disassembly) to shop floor
- Service teams create interactive animations of products using Solid Edge assemblies to train shop floor assembly personnel, co-workers and field engineers, as well as using engineering data to quickly produce technical publications for service and repair manuals

### Visualization

Rendering and animation allows companies to promote their designs internally, and helps win new business. 3D models are much more effective than 2D drawings for communicating design intent, and Solid Edge takes designs to the next level – with motion simulation tools for evaluating prototypes, advanced capabilities for showing assembly and disassembly sequences, and an advanced rendering environment for creating realistic scenes that simulate the environment in which end products will be used.



For more information, ask to see Siemens PLM Software's *Motion Simulation, Explode – Render – Animate* white paper.

KeyShot is an integrated advanced rendering application that allows Solid Edge designs to be transformed into photorealistic images. These images are ideal for use in sales and marketing collateral – allowing you and your customers to visualize a final product before manufacturing or fabrication occurs.

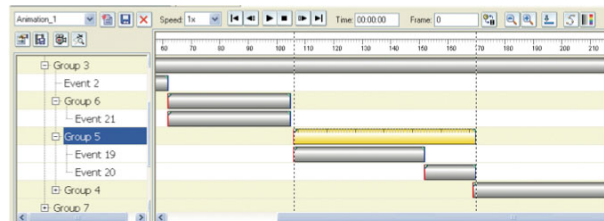

### Managed design collaboration

Globally distributed partner networks are no longer the sole domain of large OEMs. It is now common for small and mid-sized companies to participate in or even drive multiple, highly competitive supply chains, each placing rigorous demands on product development speed, quality and costs. Collaboration is critical to successful product design, and with Solid Edge software, OEMs and suppliers can improve and manage collaboration across design teams, regardless of location. By reducing design revisions and communication delays, customers enjoy better time-to-market and increased profitability.

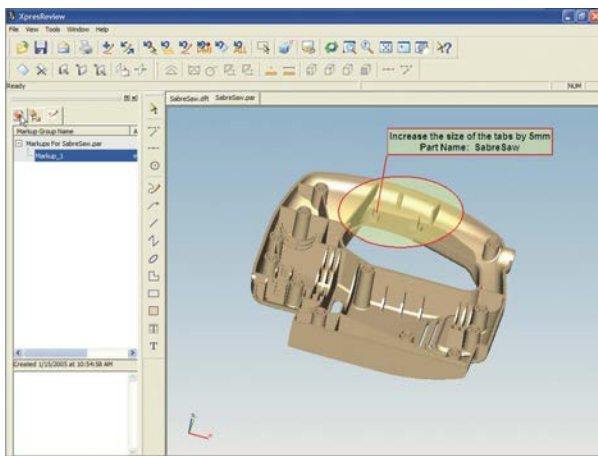

The following design collaboration capabilities are important to plant equipment layout and design. A brief description and highlights are presented below. For more details, please request the OEM supply chain collaboration white paper, available from your Channel Partner or [www.siemens.com/solidedge](http://www.siemens.com/solidedge).

Solid Edge Insight first set the standard for managed collaboration for Solid Edge on a single site. For multi-site/multi-CAD requirements, Solid Edge™ SP software is available. For collaboration, Solid Edge delivers everything from standard free viewers for viewing native data, packaged collaboration files that contain all design data in a single compressed file that can be viewed and marked up in the free XpresReview, through to the universal JT™ collaboration format.

Fully supporting both JT and PMI data, XpresReview is an electronic design review solution that allows easy sharing of multiple documents in a collaborative environment. Used independently, or in conjunction with Solid Edge or NX, XpresReview easily combines 3D models and other associated documents into a single package collaboration file (PCF), so that participants in the review process have all the information they need to communicate effectively. Recipients of the package can use XpresReview to quickly and easily interrogate its contents – viewing, measuring and marking up the data.

### Solid Edge and Femap

Solid Edge and Femap software comprise a comprehensive family of modular, yet integrated, solutions addressing the product lifecycle management (PLM) needs of the mid-market. Consisting of a preconfigured family of digital product design, analysis and data management software offerings, Solid Edge/ Femap leverages the industry's best practices to provide significant breakthroughs in ease-of-use and deployment. Mid-sized manufacturers can leverage the powerful CAD, CAM, PDM and CAE to transform their process of innovation while maintaining a low total cost of ownership.

These products are completely scalable to the full range of Siemens' industry-leading, enterprise-level PLM portfolio:

**Solid Edge** for digital product development

**Femap** for design analysis

**Solid Edge SP** for managed collaboration

**Solid Edge CAM Express** for manufacturing

Understanding that not all companies are the same, each of these products can be purchased standalone or as an integrated suite allowing you – at any time – to scale to Siemens' full complement of PLM solutions. By offering purchasing one or all of the components, the portfolio provides immediate flexibility with a predefined growth path to advanced capabilities, as your business and organizational needs grow. This cost-effective solution allows mid-sized manufacturers an entry point into PLM with a low total cost of ownership and dramatic return on investment.



# Conclusion

The problems associated with plant equipment design and layout may look daunting. Users are faced with many common problems, such as translation, modeling complete digital mockups, integrating design with manufacturing and analysis, capturing data for re-use and handling and managing massive amount of information. No matter which category a company falls under, they all strive to develop a process to mass produce a product.

A core strength of Solid Edge is addressing the needs of machine manufacturers and because of sound tools and capabilities, a natural progression has taken the product to the next level. Hybrid 2D/3D design, massive assembly support and scalable data management have made Solid Edge an excellent choice for plant equipment design and layout.

## Additional reading

For a more detailed look at the capabilities listed in this white paper or to review case studies, please ask your Channel Partner for a copy or download them directly from [www.siemens.com/solidedge](http://www.siemens.com/solidedge).

### White papers

[Solid Edge Diagramming \(1.1M, PDF\)](#)

[Solid Edge Simulation \(2.4M, PDF\)](#)

[Solid Edge Structural Frames and Weldments \(3.4M, PDF\)](#)

[Solid Edge Hybrid 2D/3D Design \(3.6M, PDF\)](#)

[Solid Edge Large Assemblies \(3.7M, PDF\)](#)

[Motion Simulation, Explode – Render – Animate \(3.5M, PDF\)](#)

[OEM Supply Chain Collaboration \(4.3M, PDF\)](#)

### Case studies

[It's canny](#) – Angelus Sanitary Can Machine Company. Solid Edge helps Angelus Sanitary Can Machine Company design machines that seal food and beverage cans at up to 3,000 cans per minute in a complex yet flawless operation.

[Brückner Maschinenbau asks a lot of its CAD software](#) – Brückner Maschinenbau GmbH. A Solid Edge customer since version 1, this Bavarian machine manufacturer knows it made the right choice.

[Machinery maker can respond more quickly to customers' requests](#) – Doucet Machineries Inc. Since implementing a standardized 3D design process, custom machinery is developed faster and designs are better.

[Productivity rises dramatically for Reading Bakery Systems](#) – Reading Bakery Systems CAD and design management give the baking equipment manufacturer a 63 percent efficiency advantage and that's just the beginning.

[3D makes plant design more efficient](#) – Siemens VAI

[Staying on top of a Chinese industry](#) – Tech-Long needed a more efficient way to design its large, complex beverage packaging machines.

## Siemens PLM Software

### Headquarters

Granite Park One  
5800 Granite Parkway  
Suite 600  
Plano, TX 75024  
USA  
+1 972 987 3000

### Americas

Granite Park One  
5800 Granite Parkway  
Suite 600  
Plano, TX 75024  
USA  
+1 314 264 8287

### Europe

Stephenson House  
Sir William Siemens Square  
Frimley, Camberley  
Surrey, GU16 8QD  
+44 (0) 1276 413200

### Asia-Pacific

Suites 4301-4302, 43/F  
AIA Kowloon Tower, Landmark East  
100 How Ming Street  
Kwun Tong, Kowloon  
Hong Kong  
+852 2230 3308

## About Siemens PLM Software

Siemens PLM Software, a business unit of the Siemens Industry Automation Division, is a world-leading provider of product lifecycle management (PLM) software, systems and services with nine million licensed seats and 77,000 customers worldwide. Headquartered in Plano, Texas, Siemens PLM Software helps thousands of companies make great products by optimizing their lifecycle processes, from planning and development through manufacturing and support. Our HD-PLM vision is to give everyone involved in making a product the information they need, when they need it, to make the smartest decisions. For more information on Siemens PLM Software products and services, visit [www.siemens.com/plm](http://www.siemens.com/plm).

## [www.siemens.com/plm](http://www.siemens.com/plm)

© 2014 Siemens Product Lifecycle Management Software Inc.

Siemens and the Siemens logo are registered trademarks of Siemens AG. D-Cubed, Femap, Fibersim, Geolus, GO PLM, I-deas, JT, NX, Parasolid, Solid Edge, Syncrofit, Teamcenter and Tecnomatix are trademarks or registered trademarks of Siemens Product Lifecycle Management Software Inc. or its subsidiaries in the United States and in other countries. All other logos, trademarks, registered trademarks or service marks belong to their respective holders.

11209-Y3 8/14 B